

TOP VIEW

TONGUE & GROOVE JOINT WITH POLYPROPYLENE BASESEALER

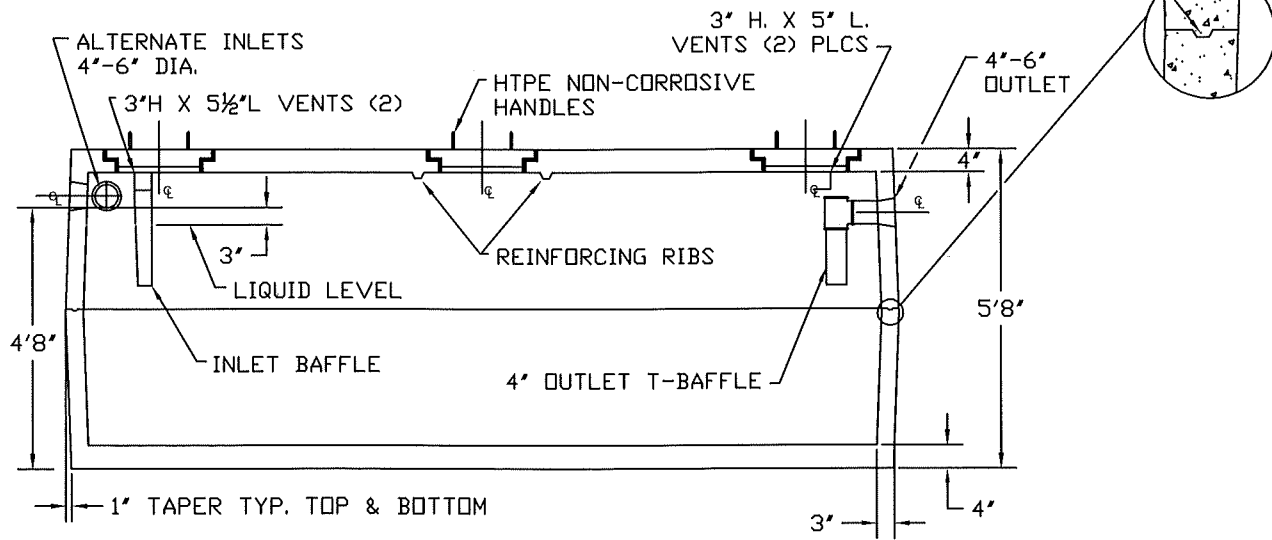

SECTION A-A

NOTES:

- EXCAVATION MUST BE AT LEAST 12" WIDER & LONGER THAN TANK SIZE.



**CONCRETE PRODUCTS, INC.**

3584 Airline Road Muskegon, Michigan 49444  
 231-733-1904 1-800-TOO-BUSH  
 WWW.BUSHCONCRETEPRODUCTS.COM

2000 Gal. Septic Tank

|                         |          |         |         |
|-------------------------|----------|---------|---------|
| SIZE                    | DATE     | DWG NO. | REV     |
| A                       | 12/14/05 | 009A    | 2/01/12 |
| DRAWN BY: S. GARABEDIAN |          | SHEET   | 1 of 1  |