

TOP VIEW

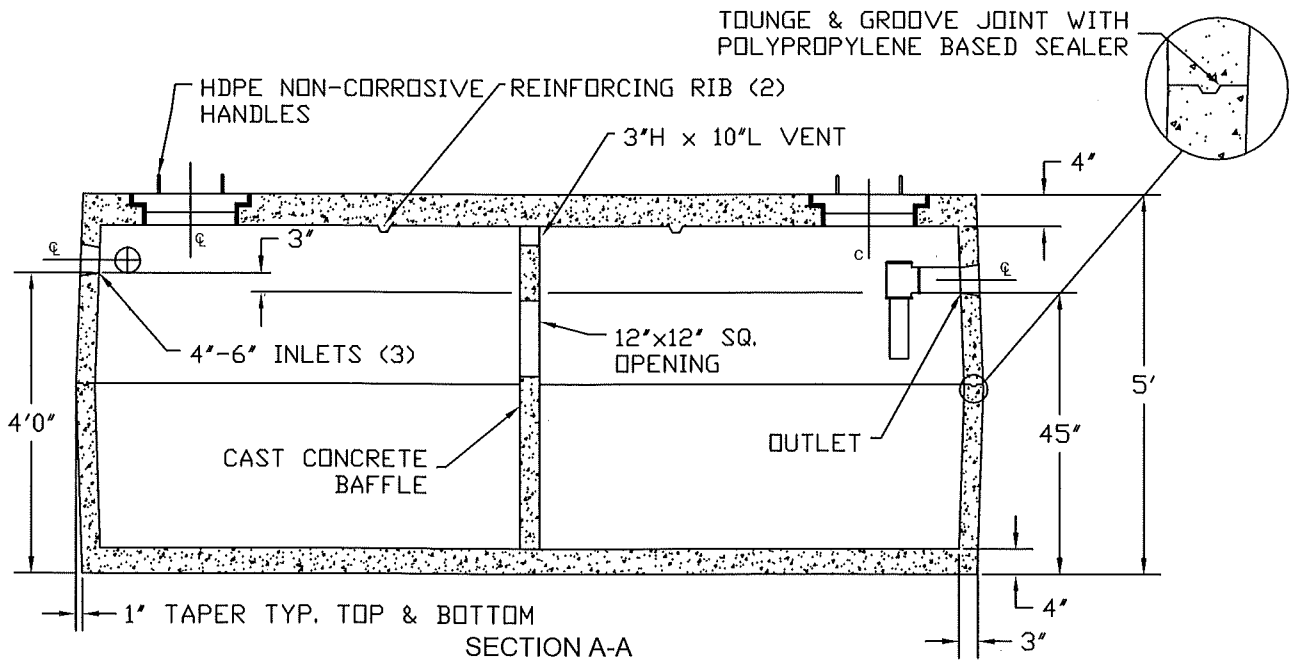

SECTION A-A

- NOTES:  
 1. EXCAVATION MUST BE AT LEAST 12" WIDER & LONGER THAN TANK SIZE.



## 1600 gal. 2 Compartment Septic Tank

SIZE	DATE	DWG NO.	REV
A	12/13/04	008	
DRAWN BY: CB 10/27/2011		SHEET 1 of 1	